



ARINC 429 Commentary

SBS Avionics Technologies

2400 Louisiana Boulevard, NE
AFC Building 5, Suite 600
Albuquerque, NM 87110-4316
Fax: 505-875-0400
Email: sbshelp@sbse.com
<http://www.sbs-avionics.com>
800-SBS-1553 or 505-875-0600

© 1999 SBS Technologies, Incorporated. All rights reserved.

ARINC 429 Commentary

This document is the intellectual property of SBS Technologies, Inc. (SBS), and contains proprietary and confidential information. Use, disclosure, and reproduction is permitted only under the terms of a software license agreement or explicit written permission of SBS. You should not use this document or its contents until you have read and agreed to the applicable software license agreement.

This document and its contents are provided as is, with no warranties of any kind, whether express or implied, including warranties of design, merchantability and fitness for a particular purpose, or arising from any course of dealing, usage, or trade practice.

In no event will SBS be liable for any lost revenue or profits or other special, indirect, incidental and consequential damage, even if SBS has been advised of the possibility of such damages, as a result of the usage of this document and the software for which this document describes. The entire liability of SBS shall be limited to the amount paid by you for this document and its contents.

SBS shall have no liability with respect to the infringement of copyrights, trade secrets or any patents by this document of any part thereof. Please see the applicable software license agreement for full disclaimer or warranties and limitations of liability.

RESTRICTED RIGHTS LEGEND

Use, duplication, or disclosure by the Government is subject to restrictions set forth in subparagraph (c)(1)(ii) of the rights in Technical Data and Computer Software clause at DFARS 252.227-7013.

SBS Technologies, Inc., 2400 Louisiana Blvd. NE, Albuquerque, NM 87110

SBS Technologies, Inc., and its logo are trademarks of SBS Technologies, Inc. All other brand names and product names contained herein are trademarks, registered trademarks, or trade names of their respective holders.



An ARINC 429 Commentary

1 Preface

Unlike military standards, the ARINC 429 Specification is not a public document. Aeronautical Radio, Inc. (ARINC) holds the copyright. Therefore, this document presents a commentary and review of the ARINC 429 Specification but does not reproduce any sections of it. We have taken the liberty to reorganize aspects of the specification that are better understood when grouped together as sections. The specific sections are:

- [Preface](#)
- [About the ARINC Organization](#)
- [Introduction To ARINC 429](#)
- [Electrical Elements](#)
- [Word And Protocol Methods](#)
- [Summary](#)

The specification itself contains numerous commentaries provided by the governing committee. These commentaries, which are intended to further explain or provide caveats to that particular area of the specification, are considered in this discussion. Small specification areas are incorporated into the discussion, while large areas are explicitly declared. This commentary is designed to provide you with a basic understanding of the ARINC 429 specification and bus functionality.

This document provides an overview of the ARINC organization and the ARINC 429 Specification. There are three parts to the ARINC Specification: 429P1-15, 429P2-15, and 429P3-15. The information in this document is an interpretation of ARINC 429P1-15. Please note that some of the terminology used in ARINC documents is a bit ambiguous. To provide a better understanding, this commentary introduces some new terminology.

2 About the ARINC Organization

ARINC itself is not a standard nor is it a piece of equipment. ARINC is an acronym for Aeronautical Radio, Inc. The ARINC organization is the technical, publishing and administrative support arm for the Airlines Electronic Engineering Committee (AEEC) groups. The AEEC was formed in 1949 and is considered the leading international organization in the standardization of air transport avionics equipment and telecommunication systems. AEEC standards define avionics form, fit, function, and interfaces. The AEEC is comprised of 27 airline and related organizations. Representatives have engineering, operational, and maintenance experience within their organization.

ARINC specifications are divided into four numbering systems and two basic types. The numbering systems include the 400, 500, 600, and 700 series. The groups are divided into general design requirements and terminal design standards (characteristics). General Design requirements include the 400 and 600 series of documents. Specific terminal design and testing criteria (characteristics) are set forth in the 500 and 700 series. The 500 series define older mostly analog avionics equipment, much of which is still used in modern aircraft with updated technologies. The 400 series documents are considered the general design and supporting documents for the 500 series avionics equipment characteristics. Similarly, the 600 series documents are considered the general design and support documents for the 700 series of avionics equipment characteristics. However, there may be some exceptions; suffice it to say that 700 series terminals are generally digital systems. The 500 and 700 series documents are equipment specific and, among other things, define how the unit shall operate, including the input and output pathways for digital and analog information.

ARINC standards define design and implementation of everything from testing requirements to navigational (NAV) systems to in-flight entertainment. Some of the newer specifications cover digital systems, testing, development, and simulation criteria. Aside from the specifications themselves, there are a number of subgroups, other avionics organizations, and private manufacturers, all of whom publish information regarding the implementation of avionics systems, e.g. the General Aviation Manufacturer's Association (GAMA), who defines subgroup functionality.

Some of the most prevalent ARINC standards are ARINC 419, ARINC 575, ARINC 429, ARINC 615, and ARINC 629. Of course, numerous others exist, and many of the 500 series are considered obsolete. Generally, three specifications define the characteristics of avionics buses: ARINC 419, ARINC 429, and ARINC 629. A few of the avionics terminal specifications define their own unique bus architecture, such as ARINC 709, which includes a high speed RADAR imaging bus. ARINC 419 is the oldest and is considered obsolete. However, it is important from a maintenance viewpoint. The vast majority of avionics terminals employ ARINC 429 for their avionics bus. Currently, only the Boeing 777 employs ARINC 629.

3 Introduction To ARINC 429

The Predecessor: ARINC 419

ARINC 419 is a collection of the various avionics buses in use at its creation. The ARINC 419 specification was the first digital communications specification for commercial aviation. This specification was developed in 1966 and last updated in 1983. ARINC 419 was created to provide a central point of reference for the different variations of buses, providing both electrical and protocol declarations. Although the 419 specification declares four different wire topologies and clock rates between transmitter and receiver, all buses use a shout bus topology (simplex) and the Label identification method for data words. The four wire topologies are described in [Table 3.1](#).

Table 3.1: ARINC 419 Topologies

Topology	Description
Parallel	One wire per bit
Six wire	One clock, one data, one sync (3 twisted shielded pairs)
Serial	One twisted shielded pair
Serial	Coaxial cable

Among the four declared, the most widely known implementation of 419 is the Serial; one twisted shielded pair topology used by the Digital Air Data System (DADS; known as ARINC 575), followed by the six wire (three twisted shielded pairs).

DADS 575 Although ARINC 419 is no longer used in terminal design and is considered obsolete, the DADS 575 twisted shielded pair bus served as the model for the ARINC 429 topology.



Note: In retrofit designs, it is not uncommon to still have the requirement to perform and/or monitor as an ARINC 419 DADS 575 line replaceable unit (LRU).

3.1 About the ARINC 429 Specification

ARINC 429 defines the Air Transport Industry's standard for the transfer of digital data between avionics systems. ARINC 429 is formally known as the MARK 33 Digital Information Transfer System (DITS) specification. The current release of the specification is known as ARINC 429-15 and is divided into the three parts shown in [Table 3.2](#) on the following page.

Table 3.2: ARINC Specification Parts

Part	ARINC Specification	Description
1	429P1-15	Functional Description, Electrical Interface, Label Assignments, and Word Formats
2	429P2-15	Discrete Word Data Formats
3	429P3-15	File Data Transfer Techniques

- Part 1 ARINC Specification 429P1-15 provides the Functional, Electrical Interface, Label and Address Assignment, and Word Format Descriptions.
- Part 2 ARINC Specification 429P2-15 provides a list of discrete word bit assignments in Label order.
- Part 3 ARINC Specification 429P3-15 describes protocol and message definitions for data block and file transfer techniques.

The ARINC 429 Specification technology had its origins in the ARINC 419 Specification, “Digital Data System Compendium” and the DADS 575 Specification. Unlike the 419 Specification, ARINC 429 defines a particular bus design and is implemented widely across virtually all modern ARINC LRU systems.

The 429
Transmission
Model
[Subsection 1.4]

The ARINC 429 specification describes the avionics bus as an “open loop” transmission model. Typically, this type of bus is described as a simplex bus with multiple receivers. Other terminology would refer to it as a “shout” or “broadcast” bus. On a 429 bus, the transmitting line replaceable unit (LRU) is known as the “source” while each receiving LRU is known as a “sink.” Any particular LRU may have multiple sources and/or sinks. A twisted shielded pair carries the ARINC 429 signal, and the sets of information are transmitted at periodic intervals. The periodic interval of data transmission must be sufficient to provide a minimal rate of change in the data, so that if a data set is lost, the loss would be of little consequence. To detect errors, the specification prescribes the use of odd parity indication and optional error checking.

Typically, a data set is composed of one word and consists of either Binary (BNR), Binary Coded Decimal (BCD), or alphanumeric data encoded per ISO Alphabet No. 5. ARINC 429 also provides for file data transfers which use more than one word. The transfer of graphic text and symbols used for CRT maps and other displays has not been defined.

A Specification,
Not a Standard
[Sections
1.1 - 1.3]

If you lack experience reading ARINC 429 documents, you should understand that ARINC 429 documents are not *standards*; they are *specifications* developed to provide a high degree of interchangeability between common functional units, typically known as LRUs. Although common implementation was the purpose of the specification on all LRUs, manufacturers are by no means required to comply.

3.2 ARINC 429P1-15 Specification

The ARINC 429 specification provides the electrical, timing, and protocol requirements necessary to implement design and proper communication on the Mark 33 Digital Information Transfer System (DITS) bus. ARINC 429 is implemented as a simplex, broadcast bus. The ARINC 429 wiring topology is based upon a 78 ohm, unbalanced, twisted shielded pair. An LRU is typically connected to the bus in a star or bus drop configuration.

Each bus has only one transmitter and up to 20 receivers; however, one terminal may have many transmitters or receivers on different buses. The transmitter sends out the 32-bit word, LSB first, over the wire pair in a tri-state clocking, Return to Zero (RZ) methodology. The actual transmission rate may be at the low or high speed of operation: 12.5 kHz (12.5 to 14.5 kHz) and 100 kHz ($\pm 1\%$). A receiver is not allowed to ever respond on the same bus where a transmission has occurred. However, since an LRU may have one or more transmitters and/or receivers (each being on a separate bus), an LRU may respond over another bus. An LRU on the ARINC 429 bus does not have an address. LRUs have equipment numbers which are then further grouped into equipment/system types. Equipment and system identification numbers are used for system management and are not typically encoded into the ARINC Word. An LRU is programmed to listen on the bus for ARINC data words. Remember, the data word begins with a Label identifying data of interest.

[2.1.1 Direction
of Information
Flow]

Transmission of information occurs from a port on the LRU that is designated for transmission only. Similarly, receive ports are used for receive only. Information cannot flow into a port designated for transmission. This is the basic definition of a simplex bus. To obtain bidirectional dataflow between LRUs, you must use at least two ARINC 429 buses.

3.3 ARINC 429 Physical Aspects

Since it is often easier to develop an understanding of a system when you have a visual/physical image of its topology in your mind, the physical aspects of ARINC 429 are presented first. Physical aspects include bus topology (how to wire the bus), transmission media, electrical characteristics, and LRU interaction.

4 Electrical Elements

This section discusses cabling, transmission characteristics, and waveform characteristics as related to Section 2.2 of ARINC 429P1-15.

4.1 Cabling

The transmission media for the ARINC 429 bus is a 78- Ω twisted shielded pair. A schematic illustration of a twisted pair appears in [Figure 4.1](#).

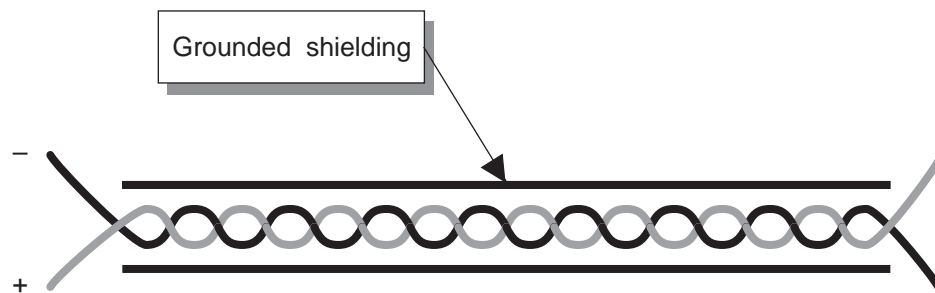

Figure 4.1: Twisted Pair

One end of the twisted pair should terminate into the data source and the other end should terminate into the data sink(s). The shields should be grounded at both ends and at all production breaks in the cable. Only a single source is permitted per bus, and a maximum number of 20 sinks may be connected. Either a star or line drop topology is permitted. A source must be capable of handling a maximum load of 400 Ω . A receiver sink must have a minimum effective input impedance of 8 k Ω . No particular bus length is specified, partially because of the direct connect nature of bus and because each sink acts like an electrical drain. Some of the newer transmitters can handle 20 receivers and over 300 feet of bus length. Most systems are designed for under 175 feet.

Choosing a
Wiring Topology

The choice of wiring topology is usually related to the distance and proximity of the sinks to the source. There are two topologies: star and bus drop. [Figure 4.2](#) and [Figure 4.3](#) show each topology.

In earlier designs, especially, the star topology was implemented. Many consider star topology safe since each LRU has its own connection to the source. Therefore, any break along a bus length results in loss of only one listener. However, the star topology requires much more wire, thus adding more weight, and also tends to create a “rats nest” within harness areas.

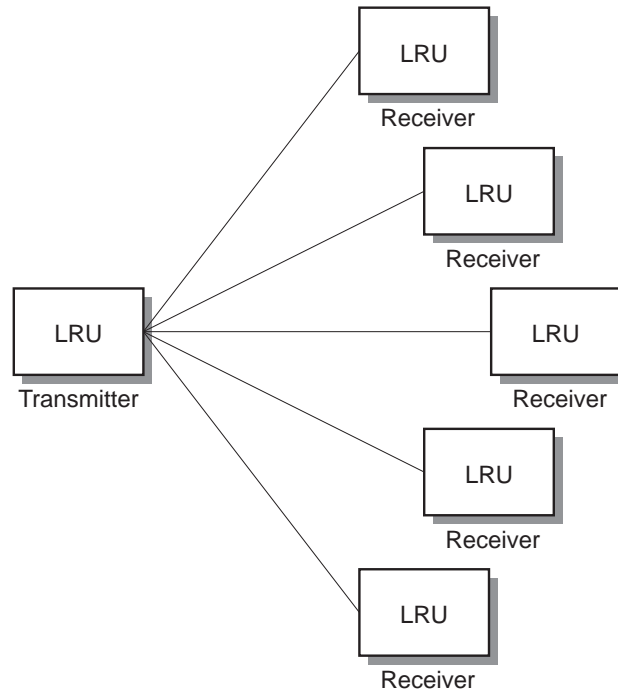

Figure 4.2: Star Topology for LRU Wiring

Therefore, many argue effectively for the bus drop topology. The same number of connections are still present, and there is a significant reduction in weight from dropping each LRU off of a central bus. Additionally, the bus drop topology avoids the rats nest issue and replaces multiple terminators with a single termination while maintaining very similar source-to-sink characteristics.

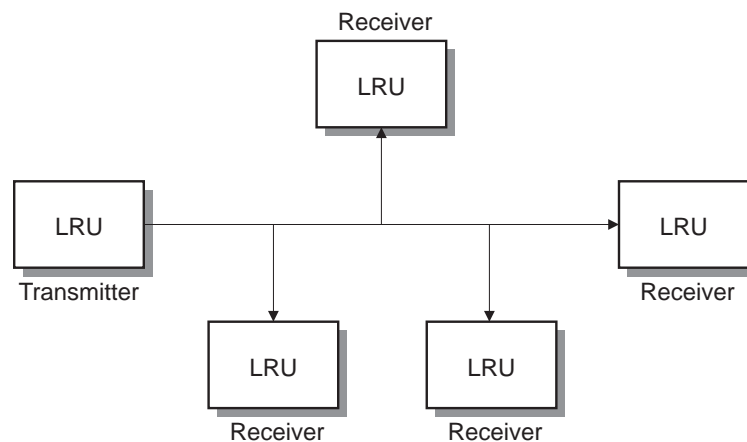

Figure 4.3: Bus Drop Topology for LRU Wiring

4.2 Transmission Characteristics

ARINC 429 has two speeds of operation: 12.5 kHz (12.5 to 14.5 kHz) and 100 kHz ($\pm 1\%$). The 32-bit word is transmitted least-significant bit (LSB) first over the wire pair with a tri-state clocking, Return to Zero (RZ) methodology. Separate words are identified by having an intermessage (or interword) gap time of at least 4 bit times, from the end of the cycle to the beginning of the next rise or fall time. A “one” is created by the transmitter when a rising edge goes from zero to 10 ± 1 positive volts, plateaus, then drops down to the zero volt line which is known as the null area (null level ± 0.5). A “zero” is created by the transmitter when a falling edge drops from zero down to 10 ± 1 negative volts, plateaus, then rises up to return to the null area. One and zero pulses are considered a complete cycle only when followed by a null area plateau as depicted by “B” in Figure 4.4. Every plateau should be of equal length.

4.3 Waveform Characteristics

The signal waveform generated is an RZ bipolar tri-state modulation. The three states are identified as “HI,” “NULL,” and “LOW.” Figure 4.4 below depicts each state. Table 4.1 lists the ARINC 429 output signal tolerances.

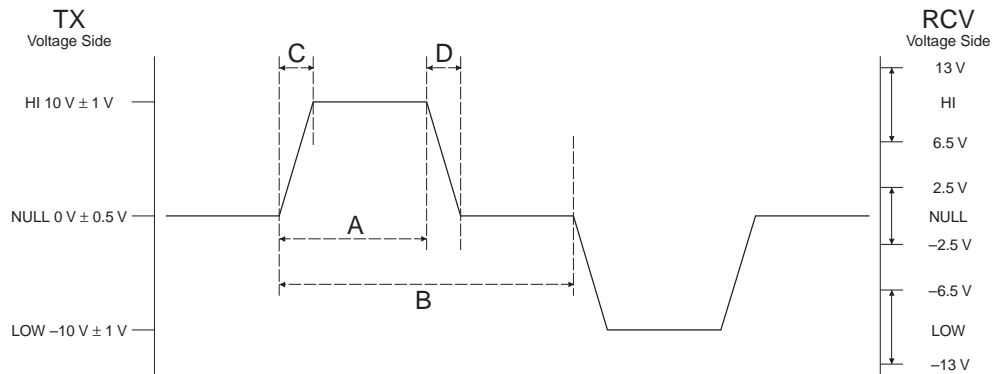

Figure 4.4: A429 Waveform Characteristic

Table 4.1: ARINC 429 Output Signal Tolerances

LTR	Parameter	High Speed	Low Speed
–	Bit Rate	100KBPS $\pm 1\%$	12-14.5 KBPS
A	1st half of pulse	5 μ sec $\pm 5\%$	B/2 $\pm 5\%$
B	Full pulse cycle	10 μ sec $\pm 2.5\%$	Z* μ sec $\pm 2.5\%$
C	Pulse Rise Time**	1.5 ± 0.5 μ sec	10 ± 5 μ sec
D	Pulse Fall Time**	1.5 ± 0.5 μ sec	10 ± 5 μ sec

* Z = 1/Bit Rate; Bit Rate is the selected rate of transmission of 12 - 14.5 KBPS

** The Pulse Rise (C) and Pulse Fall (D) times are measured between their 10% to 90% amplitude.

Transmitter
[Sections 2.2.3.1
& 2.2.4.1]

Figure 4.4 is the depiction of an ideal waveform. The figure also shows boundaries for both transmitter and receiver conditions. In order to create the wave, the transmitter needs to generate a differential output signal across the twisted pairs. The transmitter needs to be balanced to ground and should emit a differential signal, as depicted on the left-hand side of Figure 4.4. The voltages depicted are when the transmitter line is at open circuit. The voltage scale on the left shows the values that transmitters are expected to generate. Even though a valid signal should not exceed 13 volts in either direction, a transmitter should be designed to prevent a voltage transmission in excess of 30 VAC across the wire pair and ± 29 VDC from either wire to ground. Transmitters should be able to withstand indefinite shorts across the wire pair and/or to ground.

Most ARINC 429 transmitters are designed using an RC circuit to control the rise time. This implementation is preferred in order to minimize overshoot ringing, typically associated with rapid rise times. The rise and fall times are delineated by the letters “C” and “D.” The letter “A” delineates the threshold area while the letter “B” delineates the bit time area. The rise and fall times for the 100 kHz rate is 1.5 ± 0.5 μ sec while the rise and fall times for the 12.5 kHz bus is 10 ± 5 μ sec. The transmitter should exhibit a continuous output impedance of $75 \pm 5 \Omega$ in a balanced fashion between each wire of the twisted pair. Cable impedance should be selected to match the 75- Ω transmitter requirement. However, actual values from 60–80 Ω falls within the expected characteristics.

Receiver
[Section 2.2.3.2
& 2.2.5 & 2.2.6]

The voltage scale on the right of Figure 4.4 shows the values for which receivers are expected to decode. Even though the receiver should not see an amplitude any greater than ± 13 volts, each receiver should be designed to withstand steady-state voltages of 30 VAC RMS across the wire pair and ± 29 VDC from either wire to ground. In proper decoding operations, the 429 specification declares the receiver’s valid null area to be ± 2.5 V. It is not uncommon to have receivers that have a null area up to ± 3.5 V and will not decode a “one” or “zero” until the signal amplitude reaches +4.5 V or –4.5 V, respectively. These adjusted thresholds are typically implemented to overcome noise problems on the bus. On the other hand, the specification encourages designers to try a 1-volt separation between decoding values.

Most ARINC 429 receivers are designed around an operational amplifier matrix, which typically includes a clock speed identifier to establish timing requirements for differentiating high- and low-speed signals. The differential input resistance and resistance to ground of a receiver should be no less than 12,000 Ω , with a total input resistance no less than 8,000 Ω . The differential input capacitance and capacitance to ground should not be greater than 50 pF.

5 Word And Protocol Methods

5.1 The ARINC 429 Word Overview

Each sink is programmed to look only for data relevant for its operation. Relevant data is identified by the first eight bits of the ARINC word, known as the *Label*. Each ARINC 429 word consists of 32 bits with the first 8 bits (Label) octally encoded to represent the type of information contained within the 32-bit word. Figure 5.1 shows the organization of the 32-bit ARINC 429 word. A typical 32-bit word has five parts:

- 8-bit Label
- Data area
- Odd parity bit
- Source/Destination Identifier (SDI)
- Sign/Status Matrix (SSM)



Note: Usage of SDI and SSM is not mandatory.

P	SSM		Most Significant Data					DATA - 19 bits									Least Significant Data				SDI		8-Bit Octal Label								
32	31	30	29	28	27	26	25	24	23	22	21	20	19	18	17	16	15	14	13	12	11	10	9	8	7	6	5	4	3	2	1
MSB			32-Bit ARINC 429 Word																							LSB					

Figure 5.1: 32-Bit ARINC Word

Information Element [Subsection 2.1.2] The specification refers to the ARINC 429 word as the basic information element. The basic information element is composed of the data element which is categorized into five application groups:

- BNR data
- BCD data
- Discrete data [discussed in detail in Part 2 of the specification]
- Maintenance data and acknowledgment
- ISO Alphabet No. 5 and its maintenance data subset known as AIM

Subsection 2.3.1 and Attachment 6 of the specification discuss these groups in detail. Although the specification declares 5 types of data groups, there are arguably 6. The sixth data group would be the current file transfer methodology described in Part 3 of specification: Williamsburg/Buckhorn Protocol.



Note: The fifth data type, AIM, has been discontinued and replaced with the Williamsburg Protocol.

Any unused bits of a data word are required to be padded (zeros are to be placed in the bit positions).

[2.1.2 Commentary] In actual use, the basic structure of the ARINC 429 word is very flexible. The only two parts of the word needing to stay intact are the Information Identifier (Label) and the parity bit. However, earlier use of the word *did* allow the removal of the parity bit. BCD words did not use parity. When greater data resolution was required within the word, then the parity could be replaced with data.

5.2 Details

Information Identifier [Section 2.1.3] The Information Identifier is a term used in the specification to associate two different types of information: *Label* and *Equipment Identifier*. The ARINC 429 specification defines these two together as a six-character Label that provides distinct designation for any type of ARINC 429 data. This six-character Label consists of a three-character octal identifier known as the Label and a three-character hexadecimal identifier known as the Equipment Identifier. These two are listed together as part of the specification in Attachment 1 “Label Codes.” [Table 5.1](#) provides an example of the “Label Codes” table.

Table 5.1: ARINC Label Codes Example

Code No. (Octal)	Eqpt Id (Hex)	Transmission Order and Bit Position in 429 Word								Parameters	Data	
		1	2	3	4	5	6	7	8		BNR	BCD
374	005	1	1	1	1	1	0	1	1	E-W Velocity-Magnetic	X	

The Label identifies the type of information contained within BNR and BCD numeric data and the word application for discrete, maintenance, and file transfer methods (also described in ARINC 429P2 and P3). Labels can have system instruction or data reporting functionality. The structure for assigning Label numbers appears in ARINC 429P1 Appendix 5, “Guidelines for Label Assignments.”

The binary representation of the Octal Label information and its bit position within the ARINC 429 data word is seen under the “Transmission Order and Bit Position in 429 Word” heading of the table above. The most significant bit of the octal word is located in the least significant ARINC 429 bit and is transmitted first onto the bus. Since the LSB of the ARINC word is transmitted first, this causes the Label to be transmitted onto the bus in reverse bit position order. The Label is part of every ARINC 429 32-bit word, and each word begins with a Label. A Label is always transmitted in the first 8 bits of the ARINC 429 word.



Note: During data block or data file transfers, as described in ARINC 429P3-15, the Label is replaced with the System Address Label (SAL).

The Equipment Identifier (Eqpt. ID) is used administratively and identifies the ARINC 429 bus source. It must be associated with the source-sink combination. Each bus source may have up to 255 of the Labels, as defined above, assigned for its usage. Since each type of equipment (black box) has its own sets of Labels (and data) and a distinct equipment identity, the ARINC designer can use the combination of the Label and Equipment Identifier to prevent the conflict of unlike parameters having the same Label. Many times this Equipment Identifier code identifies a system on the aircraft, e.g., Ground Proximity Warning System, 023. A table of the various Equipment codes and the respective equipment type is located in Attachment 1, “Equipment Codes.”

The Equipment Identifier is not transmitted onto a bus unless the Label 377 is used. In association with that Label, the number is encoded just following the Source/Destination Identifier (SDI).

5.3 SDI

Source/
Destination
Identifier (SDI)
[Section 2.1.4]

The SDI is optional and when used, occupies bits 9 and 10 of the ARINC word. The SDI is considered to add an extension onto the ARINC word's Label, and ARINC systems are expected to decode the Label/SDI combination as a different Label than an ARINC word with the same Label and no SDI implementation.

The SDI has two functions:

1. To identify which source of a multisystem installation is transmitting the data contained.
2. To direct which sinks (destination) on a multilistener bus (known as a multisystem installation) should recognize the data contained within the ARINC word

When used in the destination function, subsystems are given an installation number: 01, 10, or 11 (binary). A zero in both bits 9 and 10 (00) conveys that all sinks on the bus should decode the data or can be used as the address for a fourth listener on the bus. An example of the multisystem destination installation appears in [Figure 5.2](#).

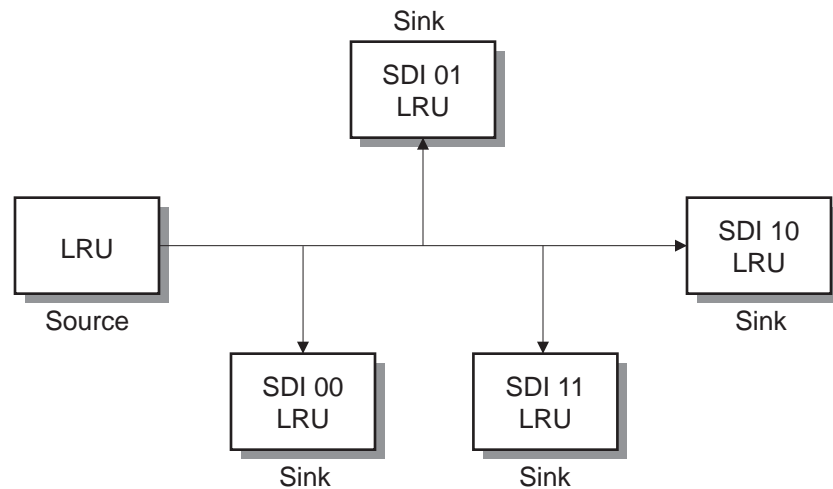

Figure 5.2: Use of SDI in Destination Mode with Multiple Sinks

As stated, the use of the SDI is optional and is not available if you are transmitting ISO Alphabet No. 5 alphanumeric data words or when additional bit resolution is needed for BNR or BCD numeric data (data requiring a higher resolution than typically provided with the 19 data bits). An example of the multisystem source identification installation is provided in [Figure 5.3](#).

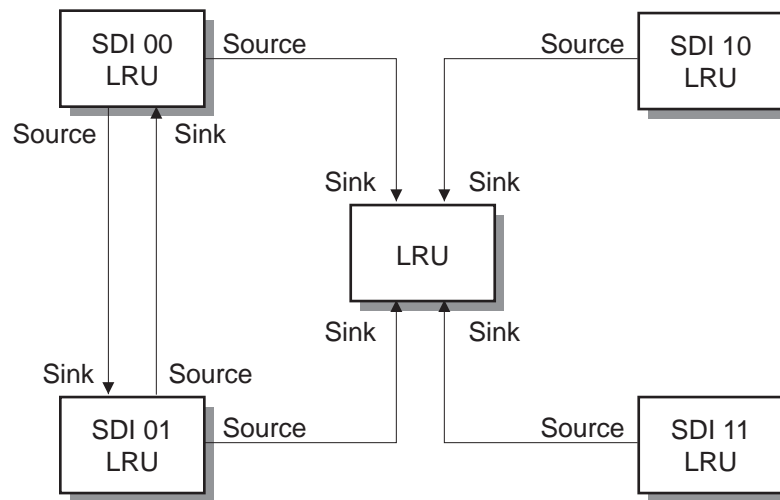

Figure 5.3: SDI Usage with Multisystem Installation

5.4 Sign Status Matrix

The Sign/Status Matrix (SSM) field may be used to report equipment conditions or the sign (+, -, north, south, east, west, etc.). Bits 30 and 31 are typically assigned to the SSM with bit position 29 also used for BNR words. In the status function, the SSM field reports hardware equipment conditions (fault/normal), operation mode (functional test), or validity of data word content (verified/no computed data).

Sign/Status
Matrix

The Sign/Status Matrix (SSM) is used for two purposes:

- To provide a sign or direction indicator for data contained within the ARINC 429 word
- To provide source equipment status information as related to the data word for the sinks

Each Label has its own unique implementation of the SSM Sign function.

When used to provide equipment status information, the SSM reports three general conditions:

1. Report hardware equipment condition (fault/normal)
2. Operational Mode (functional test)
3. Validity of data word contents (verified/no computed data)

Status information may also be accompanied by other bit settings within the data word or data within the ARINC word indicating the type of status or related values. This additional information would be specific for each system. The definitions in [Table 5.2](#) are valid for BCD, BNR, and Discrete data words.

Table 5.2: Definitions

Definition	Meaning
Invalid Data	An indication from the source to the sink(s) declaring it is unable to deliver reliable data. Invalid data includes two categories: “No Computed Data” and “Failure Warning.”
No Computed Data	This condition declares that the black box is unable to deliver valid data as related to a set of predefined events or conditions, not related to inability to compute reliable data. The exact meaning for the No Computed Data indication is specific for each black box system and is always predefined.
Failure Warning	This condition declares that black box system monitors detected one or more failures within or related to the system. The failures indications detected are specific for each black box system and are always predefined.

Functional Test status encoding is used with instruction Labels and data reporting Labels. When an ARINC word has an instruction Label and is accompanied by a Functional Test being set, then the decoding sink should interpret the instruction as a command to exercise a functional test. When the ARINC word has a data reporting Label and the Functional Test is set, the data contained within are the results of a Functional Test. Typical BCD test report data has values of 1/8th of full scale, unless otherwise defined. [Extracted from BCD section but applies to all Part 1 and 2 systems. No further discussion is presented in other sections.]

5.5 Sign/Status Matrix as Related to BCD Numeric Data [Section 2.1.5.1]

Status Reporting When encoding bits 30 and 31, the highest priority status (Priority 1) should be encoded as 11. This is used to indicate the Failure Warning. Priority 2, typically encoded as 10, is used to indicate No Computed Data. Priority 3, typically encoded as 01, is the Functional Test indicator, while 00 indicates Normal Operation.

Each LRU should cease transmission of unreliable data upon failure detection. If a system is capable of partial data resolution and the Information Identifier supports the functionality, the system may fill the unreliable BCD digits with “1111” while continuing to transmit valid data portion. Displays should show unreliable data as a dash (-) or equivalent symbol. Upon a “No Computed Data” detection, the LRU should encode into the BCD data word fields the predefined unreliable data reasons.

5.6 Sign Usage with BCD Numeric Data

Use of the Sign function is optional with BCD data. If the function is not used, bits 30 and 31 should be padded (set to zero). If the Sign function is used, then 00 stands for plus, north, east, right, to, and above. A 01 indicates “No Computed Data.” A 10 indicates the Functional Test mode, while a 11 indicates minus, south, west, left, from, and below.

5.7 Sign/Status Matrix as Related to BNR Numeric Data [Section 2.1.5.2]

Status Reporting When encoding bits 30 and 31, the highest priority status (Priority 1) should be encoded as a 00. This is assigned to indicate the Failure Warning. Priority 2, typically encoded as 01, is used to indicate No Computed Data. Priority 3, typically encoded as 10, is the Functional Test indicator, while 11 indicates Normal Operation.

If an LRU has the ability to detect a fault condition that indicates a degradation of data accuracy (i.e., input failure) and the data Label defines 17 or less data bits, the LRU shall continue to transmit a 00 in bits 30 and 31 (reporting Normal) and should encode a 1 into bit location 11 of the respective ARINC word. [Attachment 2 notes column provides detailed information.]

Sign Usage with BNR Numeric Data Use of the Sign function is optional with BNR Data and is restricted to bit location 29. If the function is not used, bit 29 should be padded (set to zero). If the Sign function is used, zero (0) stands for plus, north, east, right, to, and above, while a one (1) indicates minus, south, west, left, from, and below.

5.8 Discrete Data Words SSM Usage [Section 2.1.5.3]

Status Usage Only When encoding bits 30 and 31, the highest priority status (Priority 1) should be encoded as a 11. This is used to indicate the Failure Warning, while No Computed Data should be encoded as 01. The Functional Test indicator should set the bits to 10, while 00 indicates Verified Data, Normal Operation.

Each transmitting LRU (source) should notify its sink(s) upon detection of a fault condition that indicates a degradation of data (unreliable condition). The source has three different methods to notify its sinks:

1. Set the SSM to Failure Warning (11).
2. Cease transmission of unreliable data upon failure detection (recommended for display systems).
3. Encoding of failure condition information into the data fields. (Do not mix operational data and failure condition data.)

5.9 Datafields - 2.1.6, etc.

As shown in [Figure 5.4](#), a typical ARINC 429 word provides 19 bits for data. However, since the SDI is optional, 21 bits are available for use. Some manufacturers' custom data word configurations use only the Label and the Parity, providing 23 bits available for their data.

The specific method and organization of data for each Information Identifier appears in ARINC 429-P1, Attachment 2.

P	SSM		Most Significant Data					DATA - 19 bits									Least Significant Data		SDI		8-Bit Octal Label										
32	31	30	29	28	27	26	25	24	23	22	21	20	19	18	17	16	15	14	13	12	11	10	9	8	7	6	5	4	3	2	1
MSB			32-Bit ARINC 429 Word																								LSB				

Figure 5.4: 32-Bit ARINC 429 Word

All BCD data are encoded using bit numbers 1–4 of the seven-bit-per-character code as defined in ISO Alphabet No. 5. Alphanumeric data requires the use of all seven bits per character. (See Attachment 5 of ARINC 429P1.)

BNR data parameters are defined by first determining the parameter's maximum value, then the resolution required. The LSB of the data word is then assigned a value equal to the resolution increment. The number of significant bits for the BNR data is chosen such that the maximum value of the fractional binary series (each increment of the resolution) just exceeds the parameter's maximum value. The maximum value of the fractional binary series equals the next whole binary number that permits the presentation of the parameter's required maximum value.

For detailed information about negative numbers, two's complement fractional notation, and angular data, see Section 2.1.6 within ARINC 429P1.

5.10 Protocol

Most ARINC 429 data is transmitted integrally as part of the labeled word, i.e., Binary, BCD, Alphanumeric. However, a combination of 32 bit words may also be used in a block transfer (i.e., AIM) mode. The AIM block transfer protocol (now discontinued) was the original manner defined for data block transfer, being replaced with the Williamsburg file transfer protocol, as introduced in ARINC 429-12. The Williamsburg protocol is a bus response file transfer protocol. Williamsburg is implemented using two or more buses between two LRUs. Each LRU has a transmit bus and a receive bus, and a control protocol is implemented to manage the data transfer. In addition, these buses are point to point and are generally designed with the ability to perform under typical 429 single word transfer format.

An ARINC 429 data word has a predefined rate at which it must be retransmitted. The exact data may or may not be repeated. Most systems require data to be transmitted at the predefined transmission repeat interval whether the data has changed or not. Each Label has a minimum and maximum transmit interval that has been predefined. A Label's rate and interval are defined in the ARINC 429 specification, or in a specification by another governing body (i.e., GAMA) or by a particular avionics system supplier.

The minimum interword gap time at which ARINC 429 words can be transmitted is four bit times. As seen in [Figure 4.4 on page 8](#) (letter B) an ARINC 429 bit time consists of the positive or negative pulse and the RZ period. Four of these bit times are the minimum required to separate two ARINC 429 words. It is not uncommon to see systems designed with a standard 60- to 80-bit time intermessage gap.

[Figure 5.5](#) exemplifies how an ARINC 429 word is used when encoded for BCD information.

P	SSM		BCD CH#2			BCD CH#														SDI		8-Bit Octal Label														
																					0	0														
32	31	30	29	28	27	26	25	24	23	22	21	20	19	18	17	16	15	14	13	12	11	10	9	8	7	6	5	4	3	2	1					
MSB			DME Distance - BCD Example																								LSB									

Figure 5.5: Sample ARINC 429 Word Encoded for BCD Information

6 Summary

Although this commentary should not be used to replace the ARINC 429 Part 1 Specification, we hope the information presented in this commentary helps to clarify the specification.

For copies of the specification, please contact the following organizations:

- Aeronautical Radio, Inc.
2551 River Road
Annapolis, MD 21401
USA

- IHS
15 Inverse Way East
Englewood, CO 80112
USA

E-mail: custsvc@ihs.com

SBS welcomes your feedback about this commentary. Please direct it to:

- bschuh@sbs.com

or call 800-727-1553 extension 227.